

NEW

JS140 | MOST FUEL EFFICIENT 14T EXCAVATOR

LEADING WITH PERFORMANCE



Gross Engine Power: 75kW (100hp), Bucket Capacity: 0.63 - 0.72 cu.m
Max. Operating Weight: 14,320 kg



TOP
5
BENEFITS
FOR YOU



Reliability & Durability
Durable heavyduty structure with high quality components



Most Fuel Efficient
Savings of ₹ 1 lac per year*



High Output
Excellent digging force & productivity

10% IMPROVED efficiency
Litres per hour



Best Operator Comfort
All new cab with fully-ducted AC, as an option



Low on Maintenance
Hydraulic oil change interval of 5000 hours

*T&C Apply

MOST RELIABLE PARTNER



Durable upper frame: Rugged construction of upper frame provides durability in tough working conditions.



Heavy-duty X-frame has been designed for higher strength and durability. Belly guard protects damage to hydraulic components



Heavy-duty construction with reinforced cylinder mounting area for longer life



Strengthened arm: Strengthened boom joint and bucket joint area. Additional plate provided at the bottom for damage protection.

IP67-69 dust & waterproof connectors for electrical harness for high reliability of electricals.



BEST IN FUEL EFFICIENCY

The advanced hydraulic system has been designed for lower energy consumption which reduces fuel consumption by up to 10 % to save money for you.

Choice of Productivity (P) & Economy (E) modes :
E : Economy mode - For fuel saving with optimum productivity.
P : Productivity mode- Increased productivity through higher pump flow, when higher output is required.



Auto idler for fuel saving when the machine is not at work.



*T&C Apply.

10% IMPROVED efficiency
Litres per hour



BEST IN CLASS PERFORMANCE

XCELLENT Digging



Excellent bucket and dipper tear-out forces result in higher output and faster completion of work, especially in hard strata.

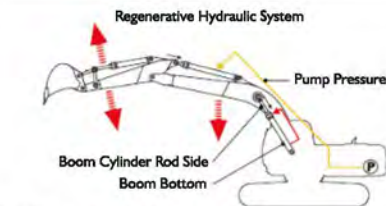

JCB's innovative hydraulic regeneration system recycles hydraulic oil across the cylinders for faster cycle times and reduced fuel consumption.

The advanced hydraulic system also ensures excellent multifunction performance, resulting in higher output levels.

Tear-out forces

**Bucket
9785 kgf**

**Dipper
7404 kgf**



LOW MAINTENANCE COST

Hydraulic oil change interval
Every **5000** hours

Special filtration system extends hydraulic life by up to 5000 hrs, with the hydraulic main return filter change intervals of 1000 hrs, which reduces maintenance costs.



Turbine type pre-cleaner assembly filters the dust particles and helps in increasing the life of the air filter elements and life of the engine.



Radial seal type air filter elements provide secure and error-free sealing. Filter elements are covered with wire mesh to avoid damage to filter paper during storage, handling and cleaning.



High capacity fuel pre-filter with water separator- to increase life of the fuel system components.



ULTIMATE EASE OF SERVICEABILITY

Compact and easy to handle bonnet is assisted by gas cylinder that helps in easy opening and closing. It makes periodic maintenance easy and effortless.

Easy to access periodic check points

Side by side radiator & cooler for ease of maintenance

Wire mesh provided to avoid clogging of radiator & oil cooler

Fuses & relays are located inside cabin and are easy to access



Boom end pivot bushes need to be greased at 1000 hours thereby reducing maintenance costs and increasing machine uptime.

A COMFORTABLE OPERATOR IS A PRODUCTIVE OPERATOR



All new cab with pressed steel construction offers increased internal space and overall visibility.



Roof hatch provided to keep the cab well ventilated, which is aided by rear sliding window.



High visibility for working at different height through front cab glass



Rubber-coated track pedal and foot rests for operator comfort. Front lower glass can be removed for ventilation.



AC option available.



Cabin is mounted on 6 viscous mounts to absorb vibrations.



BIGGER

CABIN SPACE

Spacious cab with high head and leg room

Ergonomically placed, low effort operator controls to minimize operator fatigue



*T&C Apply.

JCB Livelink - Stay Connected 24x7

SERVICE



Livelink will notify you about the service requirement of your machine. It increases the efficiency of your machine and keeps it in perfect working conditions.

Service Reminder

Reminds you when the service of your machine is due to help you plan your work better.



Machine Data Backup

Helps to maintain the records of past services in an organized manner.



Critical Machine Health Alerts

Lets you know the inside of your machine from a faraway location. Helps in taking proactive measures to avoid break down through alerts like

- Low Engine Oil Pressure
- High Engine Temperature
- Water in Fuel
- Clogged Air-filter.



OPERATION



Livelink helps you maintain your machine health and manage your fleet better by alerting you of any variation in health indicators. It lets you know in real time if your machine is facing a problem or needs any quick check-up.

Machine Utilization Report

Maintains machine usage record and helps you analyze utilization of machine.



Engine Status

Informs you if your JCB machine's engine is switched on or off.



SECURITY



Livelink helps you keep track of your machine's location, protection and movement.

GPS Tracking

Tells you the exact position of your machine on a map.



Operating Hours

Alerts you when the machine is used outside the working hours as set by you.



Tow Away Alerts

Helps you save your machine from intruders and possible tow aways.



Geofencing

Lets you keep your machine within the allocated area of work.



THE SAFEST CHOICE

Ensures machine's safety while operating. Ensures safety for operators.



Equipment protection system: Audio-Visual alerts provided in the instrument panel for following purposes:

Air filter blockage



Low coolant level



High hydraulic oil temperature

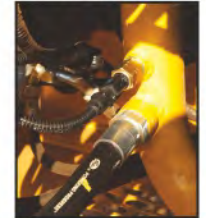

Damage Protection:

Belly guard at lower frame & undercovers for upper frame



High Visibility:

Single-piece right hand side glass and low bonnet height for high visibility leads to safer operations



Machine Safety:

Servo isolator lever over-ride system & swing lock system provides additional safety against unintended machine operations



GROSS ENGINE POWER : 100 hp
 MAX. OPERATING WEIGHT : 14,320 kgs

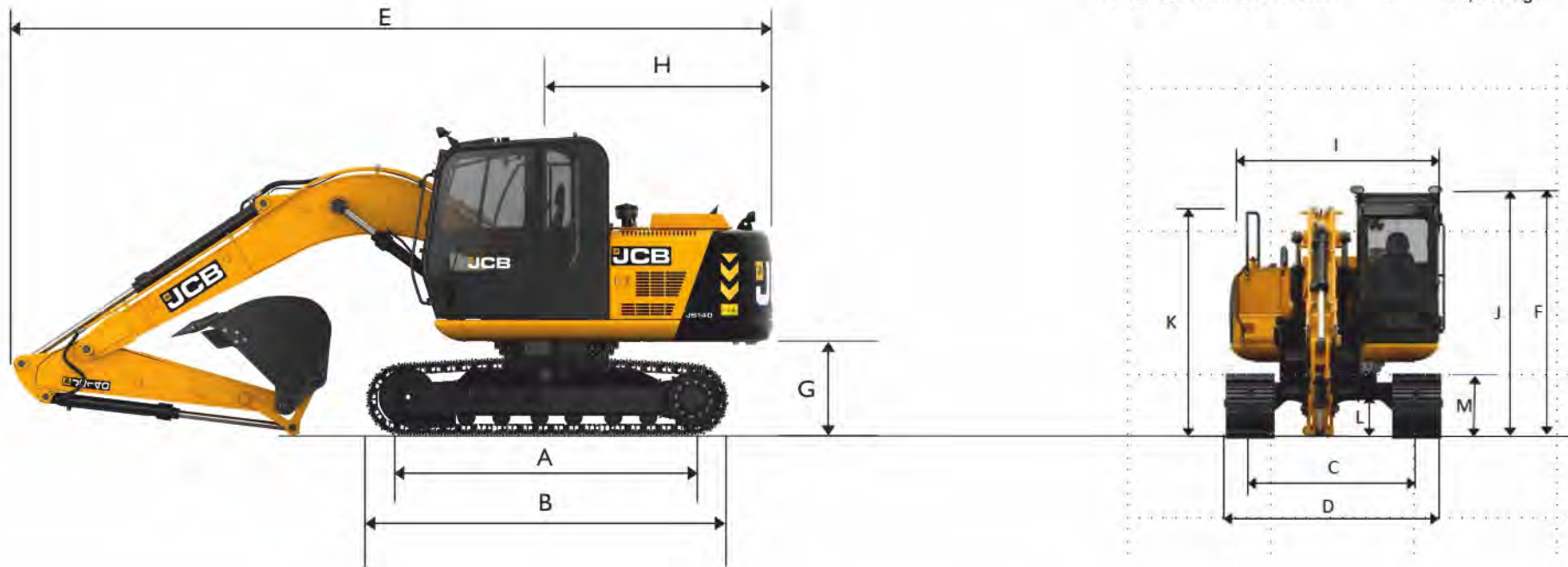

STATIC DIMENSIONS

With Boom length: 4.70m, Dipper length: 2.10m		mm
A	Track length on ground	2780
B	Undercarriage overall length	3550
C	Track gauge	1990
D	Width over tracks (500 mm trackshoes)	2490
E	Transport length with Monoboom	7630
F	Transport height with Monoboom	2997
G	Counterweight clearance	910

	mm	
H	Tail swing radius	2150
I	Width of superstructure	2410
J	Height over cab	2997
K	Height over grab rail	2622
L	Ground clearance	460
M	Track height	815

* Machine in transport position

* All dimensions, weights and timings are variable within 1.5% JCB reserves the right to change specifications without prior notice.

WORKING RANGE

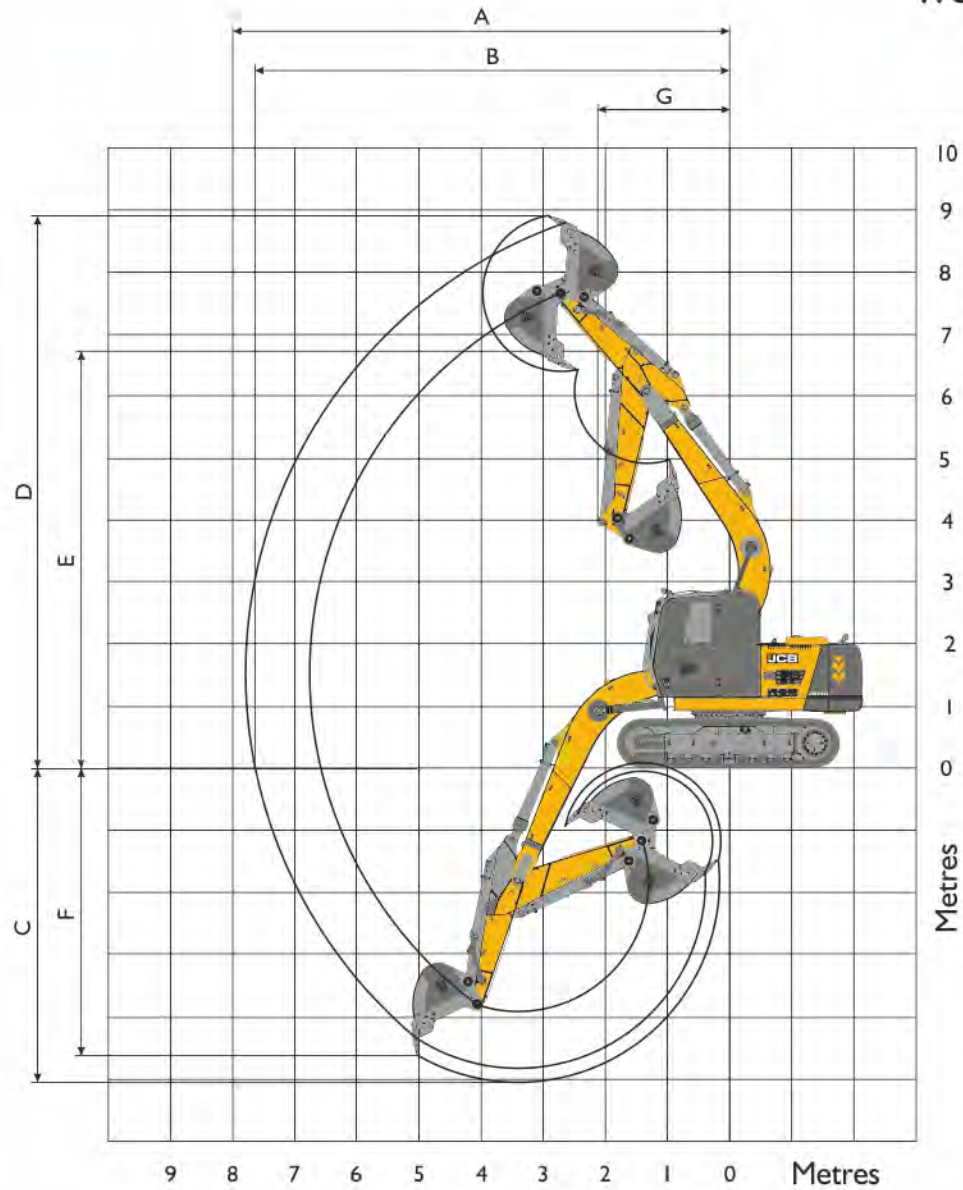

Boom length: 4.70m			
Dipper length: 2.10m			
A	Maximum digging reach	mm (ft-in)	7970 (26-2)
B	Maximum digging reach (on ground)	mm (ft-in)	7820 (25-8)
C	Maximum digging depth	mm (ft-in)	5150 (16-11)
D	Maximum digging height	mm (ft-in)	8820 (28-11)
E	Maximum dumping height	mm (ft-in)	6430 (21-1)
F	Maximum vertical wall cut depth	mm (ft-in)	4580 (15-0)
G	Maximum swing radius	mm (ft-in)	2050 (6-9)
	Bucket rotation		182°
	Maximum dipper tear out (ISO 6015)	kgf (ibf)	7404 (16569)
	Maximum bucket tear out (ISO 6015)	kgf (ibf)	9785 (20667)



* All dimensions, weights and timings are variable within 1.5% JCB reserves the right to change specifications without prior notice.

ENGINE

Model	: Cummins 4BT 3.9C.
Type	: Water Cooled, 4 stroke, 4-cylinder in line, direct injection, turbo-charged.
Gross Power	: (SAE J1995) 100hp at 2200 RPM
Net Power	: (SAE J1995) 92hp at 2200 RPM
Piston	: 3.9 litres.
Displacement	
Air filtration	: Dry element with secondary safety element
Cooling	: Water cooler via large capacity radiator with anti block 'wavy' fins.
Starting system	: 24 volt.
Batteries	: 2 x 12 volt. Heavy Duty.
Alternator	: 24 volt. 75 amp.

CAB

Press steel with high strength rolled section frame. Excellent digging, loading and positioning visibility. Parallelogram wiper. Fresh air ventilation and operator face fan. Fully adjustable deluxe suspension seat with arm rest adjustment and backrest recline.

CONTROLS

Excavator	: All servo lever operated to ISO control pattern, independently adjustable to the seat.
Tracks	: Individually servo operated by foot pedal or hand lever.
Auxiliary	: Via servo operated foot pedal.
Horn	: Operated via servo lever mounted button.

FORCES

Unmatched digger forces enable faster cycle time.

Bucket tear out force.	9785 kgf
Arm digging forces.	7404 kgf

EXCAVATOR END

Monoboam is available on the JS 140 with a 2.10 m dipper as a standard fitment. Reserve strength is built into the fully welded structures for hydraulic hammer and other arduous operations.

EXCAVATOR BUCKET

All buckets are JCB type fully-welded steel, with sealed, hardened steel pivot pins and replaceable wear parts.

Bucket size	Capacity
Max. width toe plate	
937mm	0.63 cu.m.
1071mm	0.72 cu.m.

HYDRAULIC SYSTEM

A variable flow system with flow on demand, variable power output and servo operated, multi-function open centre control.

2 Work modes: P:Productivity & E:Economy

Main pumps	: 2 variable displacement axial piston type.
Maximum flow	: 2 x 120 L/min.
Servo pump	: Gear type
Maximum flow	: 20 L/min

Control valve

A combined four and five spool control valve with auxiliary service spool, as standard. When required Twin pump flow is combined to boom, dipper and bucket services for greater speed and efficiency.

Relief valve settings

Boom / Arm / Bucket	330 bar
Swing circuit	279 bar
Travel circuit	330 bar
Pilot control	40 bar

FILTRATION SYSTEM

The hydraulic components are protected by the highest standard of filtration to ensure long hydraulic fluid life up to 5000 hrs (subject to SOS & recommended maintenance practices) and component life.

In tank	: 150 micron, suction strainer.
Main return line	: 10 micron, fibre form element.
Pilot line	: 10 micron, paper element.
Hydraulic hammer return	: 10 micron, reinforced microform element.

Cooling

Worldwide cooling is provided via a full return line air blast cooler with anti-block swing cooling fins.

SWING SYSTEM

Swing motor	: Axial piston type
Swing brake	: Hydraulic braking plus, spring applied disc type parking brake.
Final drive	: Planetary reduction
Swing gear	: Large diameter, internally-toothed fully sealed grease bath lubricated.
Swing speed	: 13.6 RPM.

UNDERCARRIAGE

Construction : Fully welded. "X" frame type with central belly guarding and sloping side members with dirt relief holes under top rollers.

Track Shoe	: 500mm (Standard)
Upper & lower rollers	: Heat-treated, sealed and lubricated.
Track adjustment	: Grease cylinder type.
Track idler	: Sealed and lubricated, with spring enhanced recoil.

No. of track guides	1 per side
No. of lower rollers	7 per side
No. of upper rollers	1 per side
No. of track shoes	44 per side

TRACK DRIVE

Type : Fully hydrostatic

Travel motors: Axial piston type, fully guarded within undercarriage frame.

Final Drive: Planetary reduction, bolt-on sprockets

Service brake: Hydraulic counter balance valve to prevent overspeeding on gradients.

Park brake: Disc type, spring applied, and automatic hydraulic release.

Gradeability	: 70% (35 deg.) continuous
Travel Speed	: 3.8 kmph
Tractive effort	: 102.6 KN (10458 kgf)

WEIGHT AND GROUND BEARING PRESSURE

Standard machine with bucket, operator	
Full capacity lubes and fuel	
Operating weight	14,320 kg
Ground bearing pressure	0.52 kg/sq.cm

STANDARD EQUIPMENT

Engine fan guard
Turbine type air pre-cleaner
Auxiliary pipe work mounting brackets
Work lights boom and mainframe mounted
Cab & counterweight mounted work lights
Undercarriage belly guarding
Upper structure under covers
Tool Kit
Handrail and non-slippery walking space
Windscreen wiper
Radiator flymesh

OPTIONAL EQUIPMENT

Livelink
Fully-ducted air-conditioned cab
FM Radio with speakers
Cab guard: Front & Top
Mirror on handrail RH
Refuel pump
Rockbreaker
Rockbreaker pipe work
Ripper tooth
Option of 0.72 & 0.63 cum buckets
Trench bucket (490mm)
First aid kit
Fire extinguisher reflectors
Cold start kit
Mirror on cab grabrail

SERVICE CAPACITIES

Fuel tank	253 lt
Engine coolant	21.2 lt
Engine oil	9.0 lt
Swing reduction gear	2.2 lt
Track reduction gear (each side)	3.0 lt
Hydraulic system	124.0 lt
Hydraulic tank	73.0 lt

* All dimensions, weights and timings are variable within 1.5% JCB reserves the right to change specifications without prior notice.

World-class manufacturing facility at Pune



India's Best & Largest Dealer Network

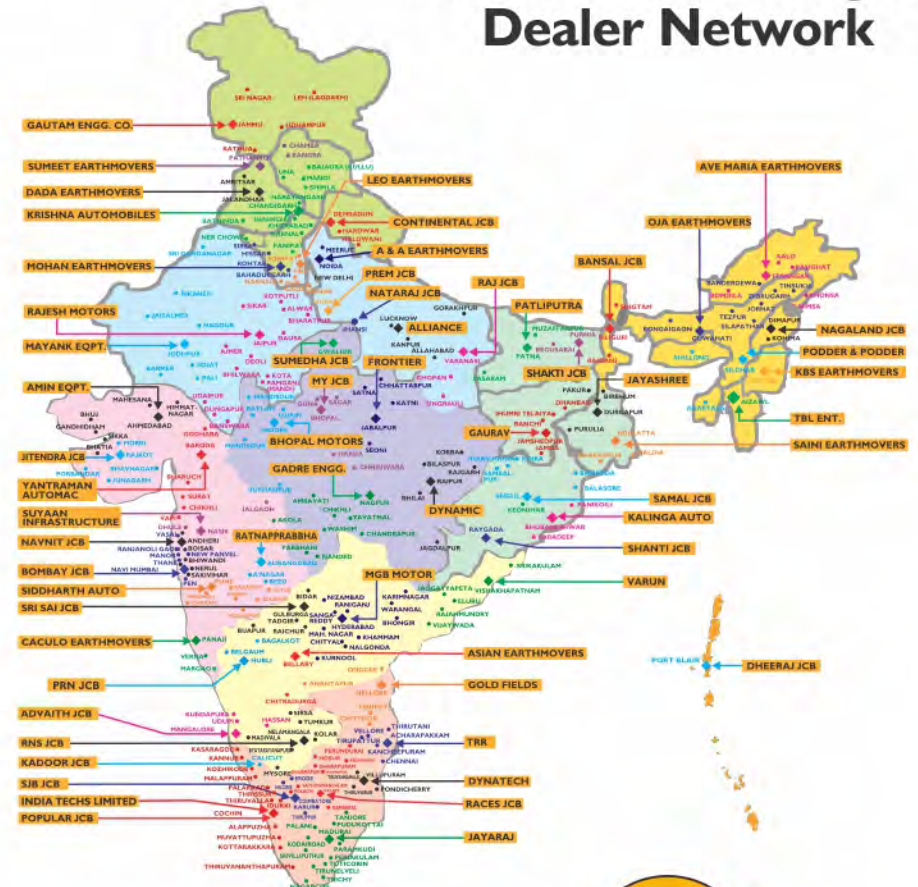

India's Leading Manufacturer of Construction Equipment



www.jcbindia.com

JCB INDIA LIMITED 23/7 Mathura Road, Ballabgarh - 121 004 Haryana, India. Fax: 91 129 2309050
For more information SMS "JCB" to **56767** or call our toll free no. **1800-2000-522**E-mail: delhi.marketing@jcb.com

Follow us:

