

SPECIFICATION

**SITE
MASTER**
THE ONE MACHINE FLEET



EXCAVATOR LOADER | 3DX ECO/PLUS/PRO

Gross power: 56-68.6kW (76-92hp) | Maximum dig depth: 4.29m | Operating weight: 7660-8185kg



SITEMASTER THE ONE MACHINE FLEET.

Our new range of 3DX Sitemaster machines boast a number of brand new features and improvements to help you master any worksite. Whichever model you choose, the world's best-selling excavator loaders are ideal for multiple applications.



SITEMASTER OF COMFORT.

A comfortable operator is a productive operator. With that in mind, we've designed an ergonomic environment with plenty of room in every operating position.

SITEMASTER OF CONTROL.

The 3DX PRO has joystick excavator controls which give superior visibility to the work area. They are also easy to use and are very familiar with excavator users.

SITEMASTER OF ALL JOBS.

Our new range of 3DX Sitemaster machines boast a number of brand new features and improvements to help you master any worksite.



SITEMASTER OF POWER & EFFICIENCY.

With powerful hydraulics and huge tearout forces, the JCB 3DX's excavator arm is designed to provide unsurpassed productivity, speed and control.

SITEMASTER OF THE ROAD.

The Easyshift transmission on the 3DX PRO makes gear changing effortless. Simply twist the console lever to change gear.

**SITE
MASTER**
OF ALL JOBS

LIVELINK, WORK SMARTER.

LIVELINK IS AN INNOVATIVE SOFTWARE SYSTEM THAT LETS YOU MANAGE JCB MACHINES REMOTELY – ONLINE, BY EMAIL OR BY MOBILE PHONE. ACCESS EVERYTHING FROM MACHINE ALERTS TO HISTORY INFORMATION, WITH ALL DATA STORED AT A SECURE CENTRE.

Productivity and cost benefits

You can monitor and manage your machines fuel level throughout the day using the analysis function. LiveLink has a comprehensive reporting tool allowing you to manage your machines up time and utilisation to get the most of your machine.

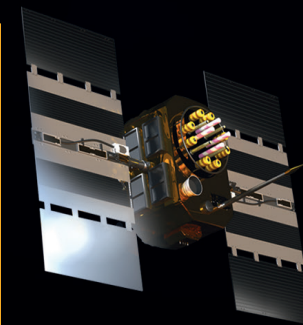

Maintenance benefits

Manage machine maintenance easily – accurate hours monitoring and service alerts improve maintenance planning, while real-time location data helps you manage your fleet. Critical machine alerts and maintenance history records are also available.



Security benefits

LiveLink's real-time geofencing alerts tell you when machines move out of predetermined zones, and real-time curfew alerts inform you of unauthorised usage, straight to your mobile phone. Further benefits include real-time location information, and LiveLink has its own internal battery and aerial.



Note: LiveLink features are model dependent, check machine specifications.

ECO



PLUS

The 3DX PLUS has a powerful 68.6kW Turbo engine with high torque, providing high performance loading on site and on the road.

PRO



ECO

The 3DX ECO features a high performing 56kW engine, providing high torque with maximum efficiency. This makes it the ideal site machine.

PLUS



PRO

The 3DX PRO is the ultimate performing machine with easy to use controls and many automation features, designed to improve productivity and fuel consumption.

STATIC DIMENSIONS

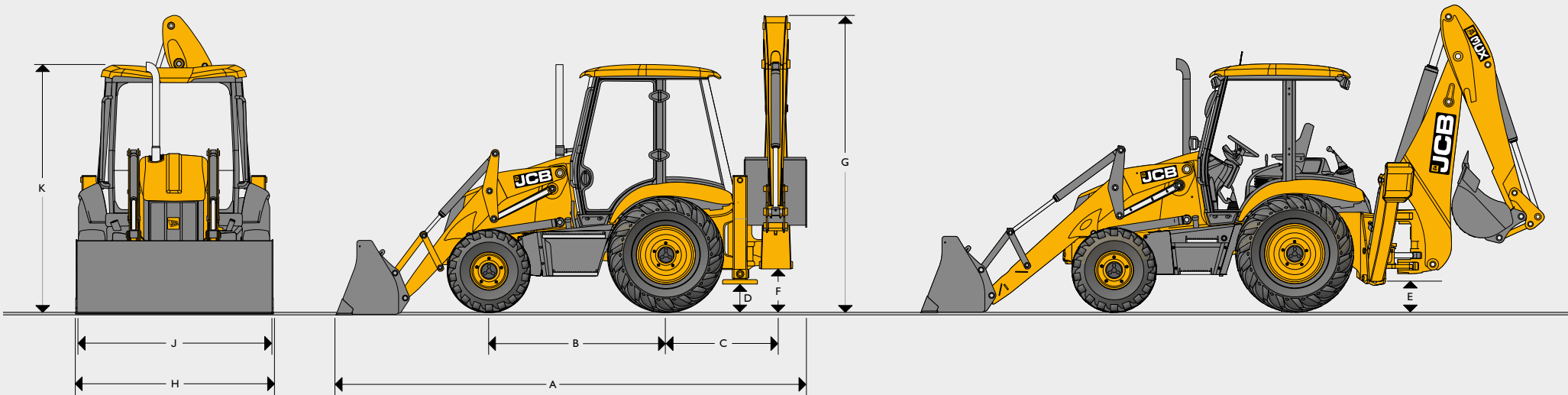

			3DX ECO sideshift	3DX ECO centremount	3DX PLUS sideshift	3DX PLUS centremount	3DX PRO sideshift
A	Total travel length	m	5.90	7.19	5.96	7.19	5.90
B	Wheelbase	m	2.25	2.35	2.25	2.35	2.25
C	Slew centre to rear axle centre	m	1.32	1.32	1.32	1.32	1.32
D	Minimum ground clearance (stabiliser foot clearance)	m	0.31	0.32	0.31	0.32	0.31
E	Ground clearance – mainframe		0.50	0.46	0.50	0.46	0.50
F	Slew ground clearance	m	0.51	0.51	0.53	0.51	0.53
G	Total travel clearance	m	3.61	3.43	3.61	3.43	3.61
H	Shovel width	m	2.23 (6-in-1 shovel) / 2.35 (GP shovel)		2.23 (6-in-1 shovel) / 2.35 (GP shovel)		2.23 (6-in-1 shovel)
J	Rear frame width	m	2.24	2.24	2.24	2.24	2.24
K	Rear frame width	m	2.88	2.91	2.88	2.91	2.88

EXCAVATOR/LOADER PERFORMANCE

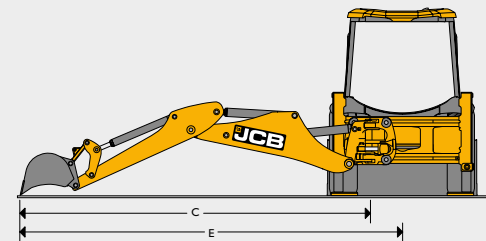
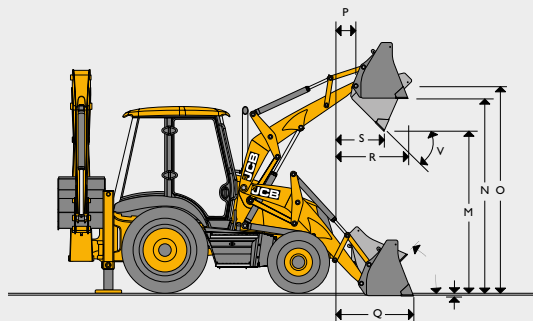
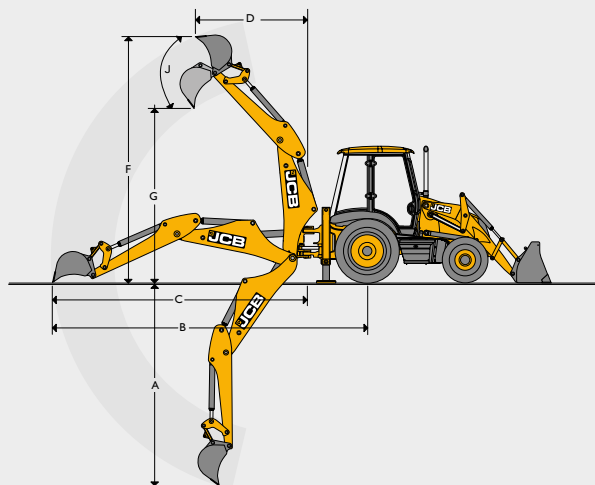

Excavator performance		3DX ECO sideshift	3DX ECO centremount	3DX PLUS sideshift	3DX PLUS centremount	3DX PRO sideshift
A	Max dig depth	m	4.29	4.29	4.29	4.29
B	Reach-ground level to rear wheel centre	m	6.67	6.67	6.67	6.67
C	Reach-ground level to slew centre	m	5.33	5.32	5.33	5.33
D	Reach at full height to slew centre	m	1.94	1.94	1.94	1.94
E	Side reach to centre line of machine	m	5.85	-	5.85	5.85
F	Max. working height	m	5.23	5.23	5.23	5.23
G	Max. load over height	m	3.57	3.57	3.57	3.57
J	Bucket rotation – power	degrees	203°	203°	203°	203°
	Boom rotation	degrees	180°	180°	180°	180°
	Bucket breakout force	kgf	5700			
	Bucket capacity		0.17m ³ /600mm			
Loader performance						
M	Dump height	m	2.91		2.91	2.91
N	Load over height	m	3.35		3.35	3.35
O	Pin height	m	3.59		3.59	3.59
P	Pin forward reach	m	0.21		0.21	0.21
Q	Reach at ground	m	1.33		1.33	1.33
R	Max. reach at full height	m	1.0		1.0	1.0
S	Reach at full height – bucket dumped	m	0.73		0.73	0.73
T	Below ground level dig depth	m	0.1		0.1	0.1
U	Rollback at ground	degrees	45°		45°	45°
V	Dump angle	degrees	43°		43°	43°
	Shovel breakout force	kgf	6219 (GP shovel) 6010 (6-in-l shovel)			
	Shovel capacity		1.0m ³ (6-in-l shovel) / 1.1m ³ (GP shovel)			
	Lift capacity to full height	kg	3495			

ENGINE	3DX ECO sideshift	3DX ECO centremount	3DX PLUS sideshift	3DX PLUS centremount	3DX PRO* sideshift
Model	JCB 448, 4 cylinder, water cooled, diesel, naturally aspirated	CB 448, 4 cylinder, water cooled, diesel, naturally aspirated	JCB 444, Turbocharged, 4 cylinder, water cooled, diesel	JCB 444, Turbocharged, 4 cylinder, water cooled, diesel	JCB 444, Turbocharged, 4 cylinder, water cooled, diesel
No. of cylinders	4	4	4	4	4
Displacement	4.8 litres	4.8 litres	4.4 litres	4.4 litres	4.4 litres
Gross power	56kW (76hp) @ 2200rpm	56kW (76hp) @ 2200rpm	68.6 kW (92hp) @ 2200rpm	68.6 kW (92hp) @ 2200rpm	68.6 kW (92hp) @ 2200rpm
Max torque	305Nm @ 1100rpm	305Nm @ 1100rpm	408Nm @ 1200rpm	408Nm @ 1200rpm	408Nm @ 1200rpm

*Auto stop automatically shuts off the engine when idle after 6 minutes, saving on wear and tear and also reducing fuel usage.

Auto idle reduces fuel consumption and unnecessary wear and tear by automatically reducing engine rpm to low idle after 10 seconds if no hydraulic services are active.

ECO/Power mode limits hand throttle speed to 1500rpm to reduce fuel consumption by up to 10%. Plus mode allows engine speed to be increased to 2200rpm to increase productivity by up to 8%.

SERVICE CAPACITIES				
		3DX ECO sideshift	3DX PLUS, 3DX PRO sideshift	All centremount models
		4WD	4WD	4WD
Cooling system	ltr	17.5	20	18.5
Fuel tank	ltr	128	128	130
Engine oil with filter	ltr	15	20	15
Gearbox with filter	ltr	20	20	16
Rear axle	ltr	20	20	16
Front axle	ltr	20	20	16
Hydraulic system incl. tank	ltr	120	120	88

TRANSMISSION

JCB Synchro-shuttle transmission: It provides superb drive power in all conditions. It consists of a 4-speed, full synchromesh gearbox with integral torque convertor and electrically operated reversing power shuttle.

- Easy-to-use, column mounted electric reversing shuttle which can change machine direction while allowing operator to keep hands on the steering wheel leading to fast cycle times.
- The pedal layout and conventional 4-pattern gear lever with transmission disconnect switch adds to the overall ease of operation. On-the-move gear changes are possible.
- Torque convertor stall ratio is 3.01:1 (2WD), 2.52:1 (4WD).

JCB EasyShift (3DX PRO): Ease of operation for better productivity with effortless gear shift.

- Easy to use, low effort column mounted electric gear change.
- On-the-move gear changes are possible.
- Semi automatic kick down on loader lever. While loading in second gear, operator can shift to first gear with push of a button, and automatically shift to second gear as soon as reverse gear is engaged.
- Gear indicator shown digitally on front display console.

	3DX ECO	3DX PLUS	3DX PRO
Manufacturer	JCB	JCB	JCB
Type	Synchroshuttle	Synchroshuttle	EasyShift
Gears forward/reverse	4 forward / 4 reverse	4 forward / 4 reverse	4 forward / 4 reverse
Shuttle control – F/R	Power shuttle	Power shuttle	Power shuttle
Travel speeds*	kph	kph	kph
Gear 1	5.7	5.7	5.7
Gear 2	11.7	11.7	9.2
Gear 3	22.0	22.0	19.8
Gear 4	40.0	40.0	40.0

*Speeds may vary dependant on tyre selection.

TURNING CIRCLE

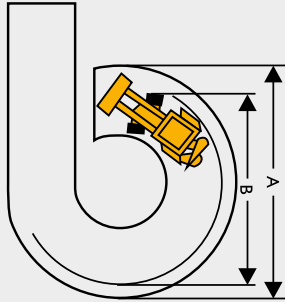

* Standard bucket in travel position

Inner wheels braked

	4WD
A Outside loader bucket	4.89m
B Outside wheels	3.60m

Inner wheels not braked

A Outside loader bucket	5.45m
B Outside wheels	4.16m

STEERING	Front wheel full power hydrostatic system utilising the main hydraulic pump via a steering priority valve. In the event of engine failure, emergency steering is maintained (all models).																
BRAKES	<p>Service: Hydraulically actuated dual line, self adjusting, oil immersed, multi-disc type on the rear axle, well protected from dirt, water etc. requiring no maintenance.</p> <p>Parking: Hand operated, disc brake on rear axle input disc.</p> <p>Brake pedal: Two independently operable foot pedals enable machine to manoeuvre in tight spaces. Pedals are linked together for normal use.</p> <p>2WD / 4WD: Electrical selection between 2WD / 4WD allows on-the-move changes.</p>																
CAB	Fully adjustable seat and soft touch steering wheel • 'Walk through' two door access • Seat belt, large convex rear view mirror, interior light front screen wiper, horn, hazard warning system, tool box • Instrumentation panel includes engine speed, engine hours, speedometer, fuel level, water temperature gauge and 12v connection • Audible and visual fault warning system for alternator charge, coolant temperature, engine oil pressure, blocked air filter, transmission oil pressure and temperature, and hand brake on • Air conditioning standard on 3DX PLUS and PRO.																
AXLES	<p>Rear: Drive axle rigidly mounted, incorporates JCB Max-Trac torque proportioning differential, driven by short propshaft from gear box.</p> <p>Front: 4WD, Steer axle, centrally pivoted with oscillation angle of 16°.</p>																
ELECTRICAL AND INSTRUMENTATION	<p>12 volt negative ground, utilising wiring and connectors meeting IP69 water ingress test standard. Central fuse panel.</p> <p>LiveLink standard on all models • Bluetooth radio standard • Guide me home lights switches on the external lights for 30 seconds to assist operator to walk safely after parking machine.</p> <p>Battery: 130 A/hr, 900 CCA. Alternator: 90 amp standard. Front working lights: 2 fixed. Rear working lights: 2 fixed and 2 adjustable</p> <p>3DX PRO additional standard features: LED lights • 6 x roof mounted air vents.</p>																
TYRES (TUBED TYPE)	<p>4WD</p> <p>Front: 12.5x18-12 ply</p> <p>Rear: 16.9x28-12 ply</p>																
OPERATING WEIGHT	<p>Sideshift models: 3DX PLUS/PRO: 7800kg</p> <p>Centremount models: 8185kg</p>																
HYDRAULIC SYSTEM	<p>JCB vari-matic hydraulics • Main relief valve: 228bar • Unloader valve: 207bar • Filtration through suction strainer and return line JCB Filtermatic filter • During excavation the circuit automatically varies hydraulic power to match digging conditions for extra performance, control and power • Careful routing of hydraulic hoses and pipework guards against site damage and allows easy servicing • JCB diagonal (X) pattern controls.</p> <p>3DX PRO has Servo controls (SAE pattern) as standard and Smooth Ride System (SRS) reducing material spillage and bounce during travel by damping out forces imposed on the machine and loader arms.</p> <table border="1"> <thead> <tr> <th></th> <th>3DX ECO</th> <th>3DX PLUS</th> <th>3DX PRO</th> </tr> </thead> <tbody> <tr> <td>Pump</td> <td>Gear</td> <td>Gear</td> <td>Variable flow piston</td> </tr> <tr> <td>Flow (lpm)</td> <td>108</td> <td>123</td> <td>125</td> </tr> <tr> <td>Pressure (Bar)</td> <td>228</td> <td>228</td> <td>270</td> </tr> </tbody> </table>		3DX ECO	3DX PLUS	3DX PRO	Pump	Gear	Gear	Variable flow piston	Flow (lpm)	108	123	125	Pressure (Bar)	228	228	270
	3DX ECO	3DX PLUS	3DX PRO														
Pump	Gear	Gear	Variable flow piston														
Flow (lpm)	108	123	125														
Pressure (Bar)	228	228	270														



ONE COMPANY, OVER 300 MACHINES.

Your nearest JCB dealer

EXCAVATOR LOADER 3DX ECO/PLUS/PRO

Gross power: 56-68.6kW (76-92hp) Maximum dig depth: 4.29m Operating weight: 7660-8185kg

JCB Sales Limited, Rokeceter, Staffordshire, United Kingdom ST14 5JP.

Tel: +44 (0)1889 590312 Email: salesinfo@jcb.com

Download the very latest information on this product range at: www.jcb.com

©2021 JCB Sales. All rights reserved. No part of this publication may be reproduced, stored in a retrieval system, or transmitted in any form or by any other means, electronic, mechanical, photocopying or otherwise, without prior permission from JCB Sales. All references in this publication to operating weights, sizes, capacities and other performance measurements are provided for guidance only and may vary dependant upon the exact specification of machine. They should not therefore be relied upon in relation to suitability for a particular application. Guidance and advice should always be sought from your JCB Dealer. JCB reserves the right to change specifications without notice. Illustrations and specifications shown may include optional equipment and accessories. All images are correct at time of print. The JCB logo is a registered trademark of J C Bamford Excavators Ltd.

